

FNAL

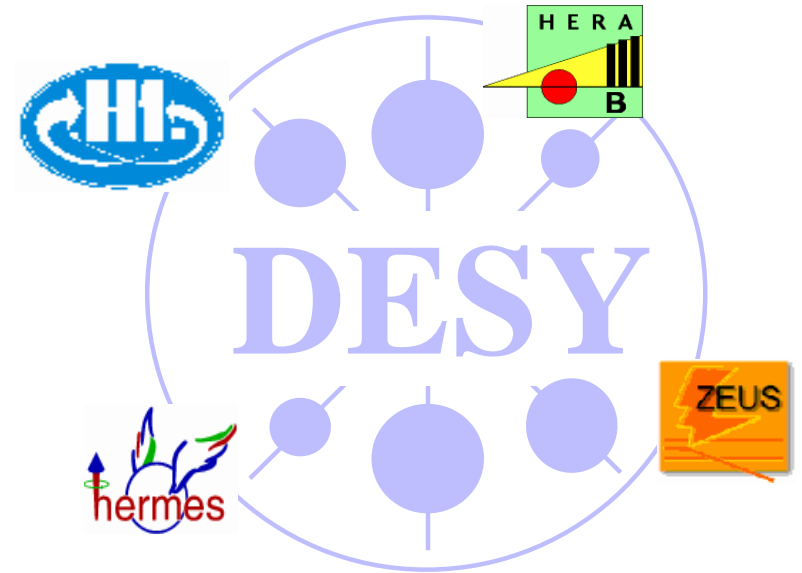

Patrick Fuhrmann, DESY IT



Cache Chain

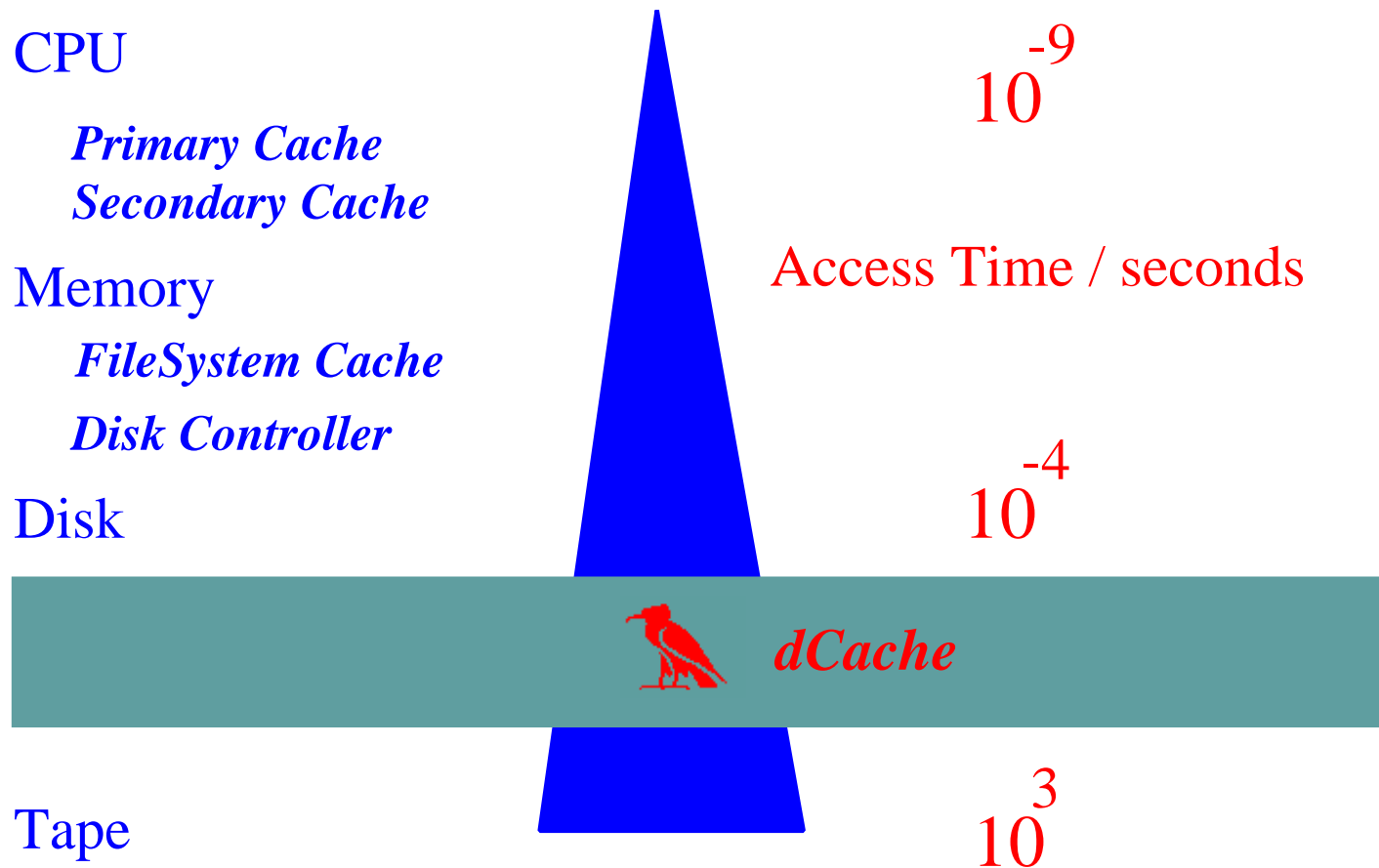

Product Placement

Network Clients

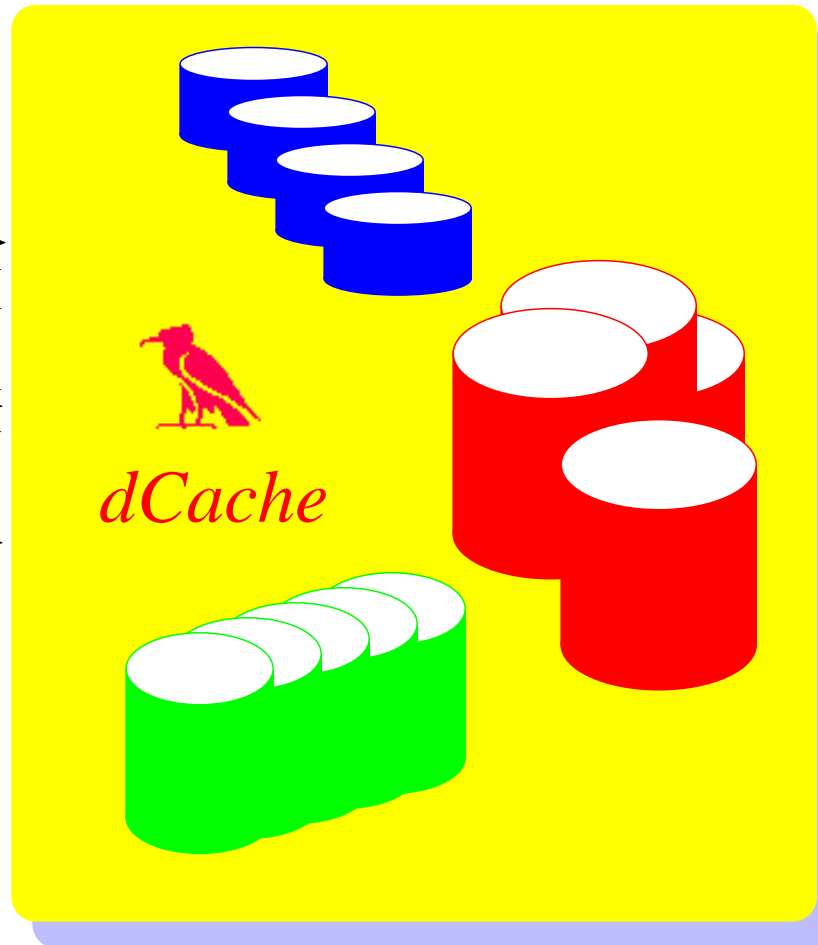
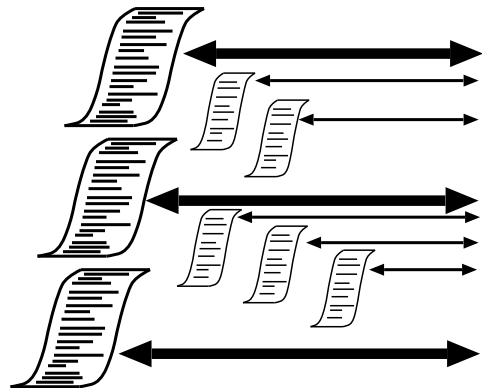

Tertiary Storage

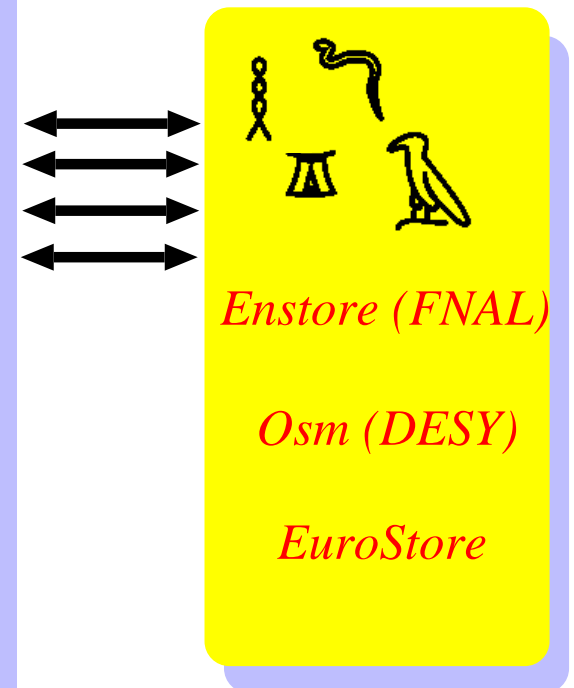

Primary Goals

Tertiary Storage View

Minimized mount/dismount operations

Predictable datarates (streaming tapes)

Use of cheap (slow) tape/robot devices

Client View

Random Repository Access

Random File Access

Arbitrary Transferrate



First Order Solution



Transferrate Adaption

Deferred Write

File Staging

[Read Ahead (Dump Tape)]



Rate Adaption

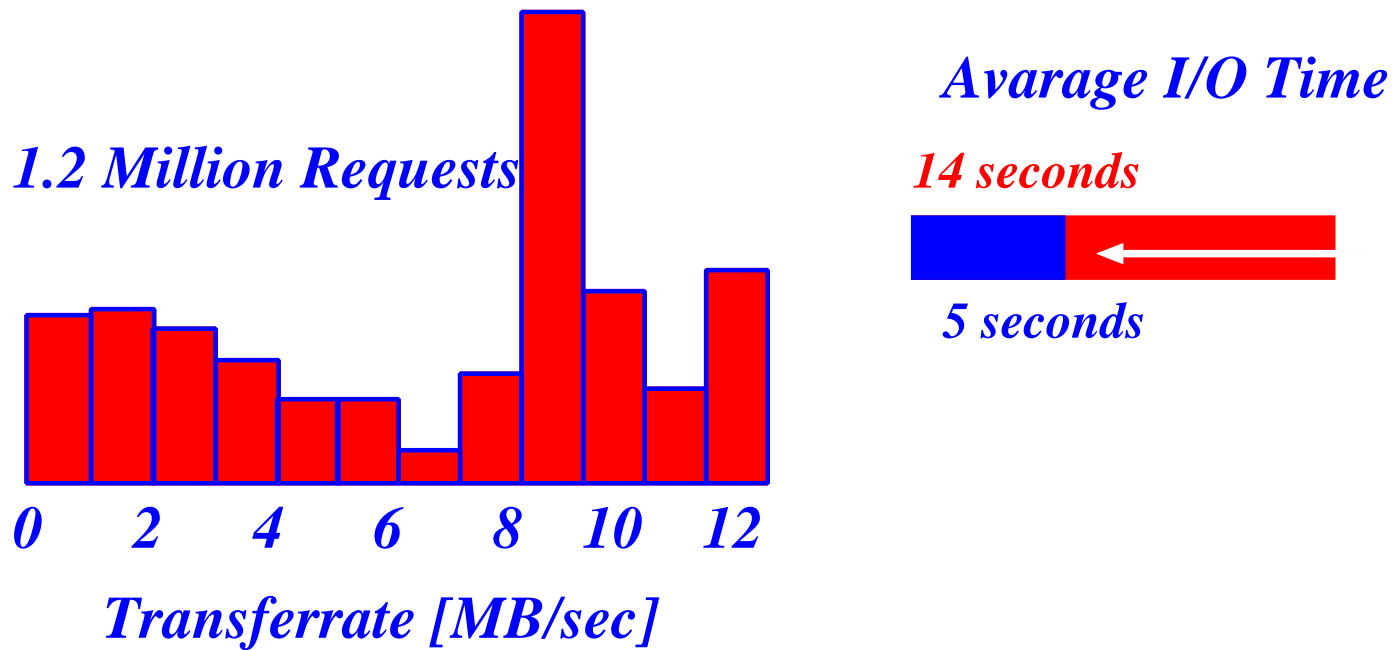

*30 % 'tape/drive busy' time reduction
mount/dismount included*



Deferred Write

- * collecting data per storage class*
- * waiting 4 hours or for 10 GB per SC*

550,000 Write Requests



20,000 Mounts

- * 70 GBytes max space used*



Staging

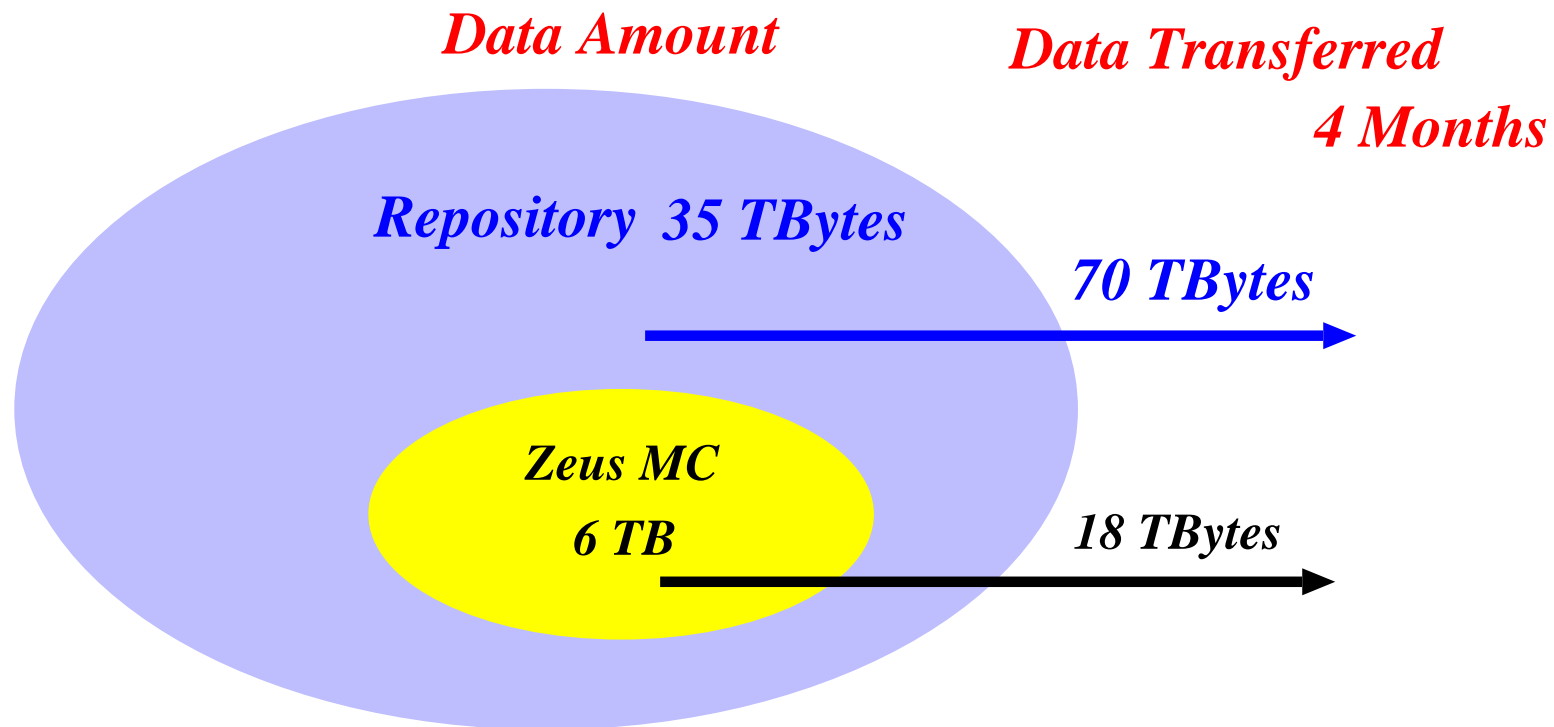

Technical Spec's

*Servers : 100 % pure Java
runs everywhere*

*Highly Scalable
1000's clients
100's Data Pools*

*Pluggable Protocol Modules
ftp, dCap, http, snmp, PDGrid ...*

*Zero Maintenance Downtime
Due To
in vivo software update*



Pluggable Protocol Engines

Network Clients

Nfs
NameSpace only

Ftp

dCap

PD-GRID

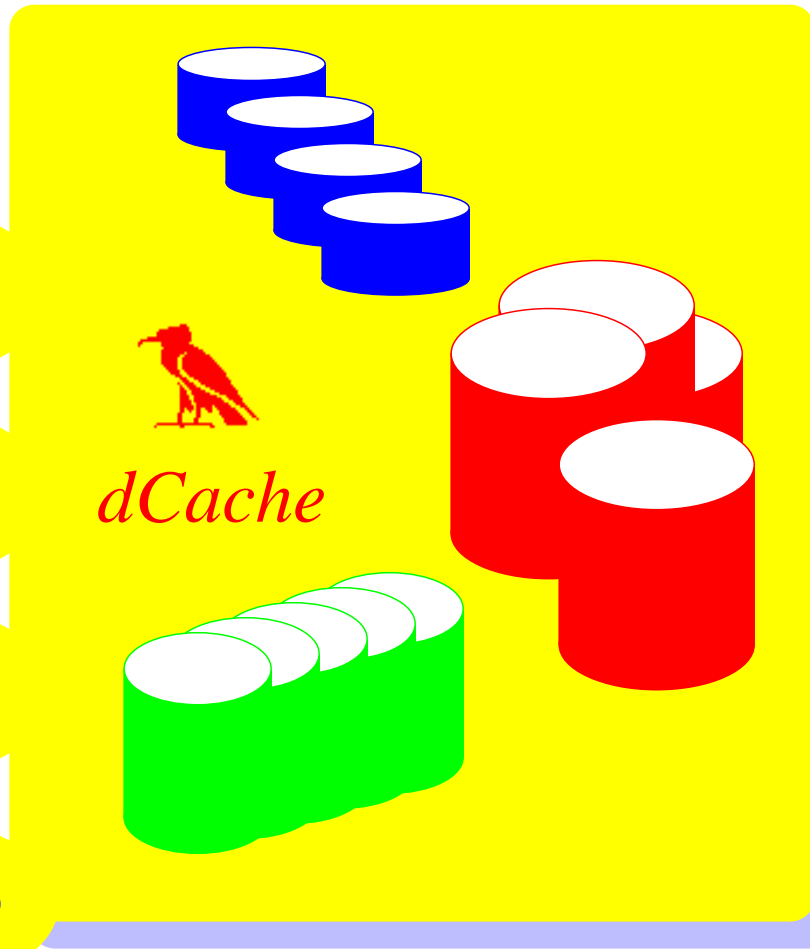

Storage Manager

Enstore

EuroStore

Osm

AnyThing



Pool Preference Model

Phase I

Pool Preference is based on a combination of

Storage Class (HSM)

Directory Tags (Filesystem)

IP number / subnetmask (network topo)

I/O Direction

allows

local pools

sticky files/pools

stack of fallback pools

site internal <-> external pools

high speed pools (limited concurrent connections)



Pool Preference Model (cont.)

Phase II

Dynamic Selection is based on

Space Cost

CPU cost (load)

no pool ok -> Phase I

Multi Residence of datasets (load sharing)



Filenamespace

Single unique filename entry for

file on HSM only

file on HSM and one pool

file on HSM and multiple pools

Accessible through 'nfs' and 'ftp'



Administration

Access

Command line interface using standard 'ssh' application

GUI using 'ssh' protocol

Web administration using 'ssl'

Central Administration Door

Access Control Lists

Delegation of Responsibilities



dCap client library

Posix Like open/read/write/select/close calls

Supports local, pnfs and URL fs notation

Tunable I/O buffer size (per data stream)

Automatic Reconnect on pool failures.

One control connection for all data connections

Supports multiple servers

Thread Save (Irix,Solaris Linux)

Suppression of 'seek' and optimized 'seek and read'

Preload library for solaris and irix



Redundancy

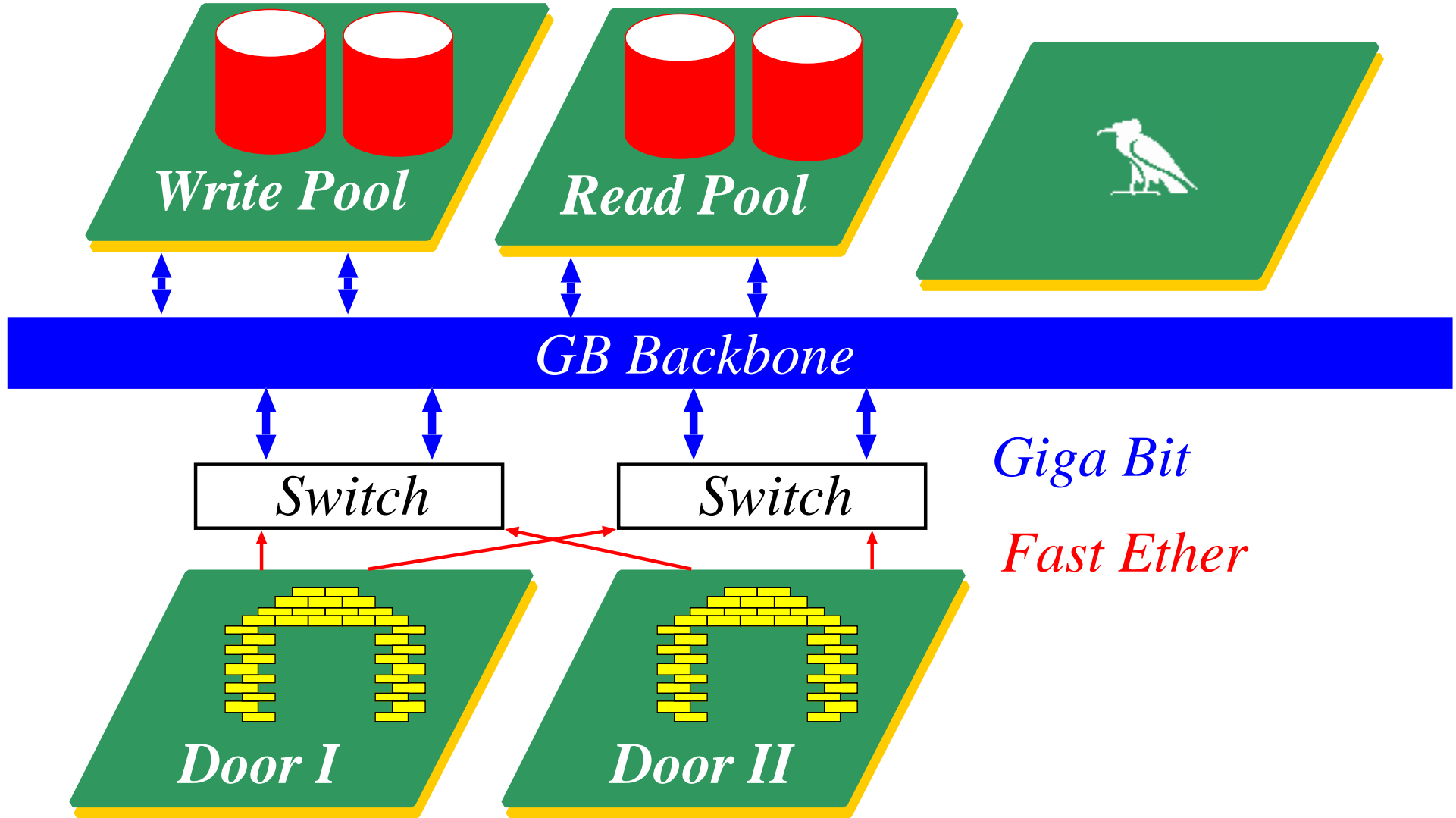

You provide

Interface to your tertiary storage
Enough (distributed) disk space

dCache provides

Unique filenamespace of your HSM repository
through 'nfs' and 'ftp'

Data access through 'ftp' and 'dCap' library

Automatic migration, staging, rate adaption
and deferred write

Admin and monitor interfaces (snmp, web, ssh)



www-dcache.desy.de

White Paper

dCap protocol Spec.

Newletters (progress reports)

